

Frame Information

GJ Series

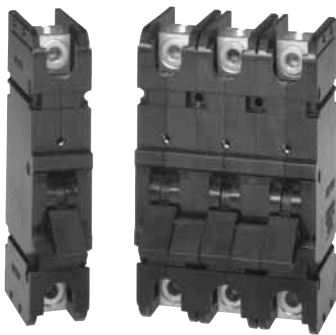

Heinemann Series GJ Circuit Breakers are the logical choice for high-current service entrance and panelboard installations, as well as control and protection of commercial and industrial lighting, transformers, motors and power supplies. The precisely tailored time delays and ability to interrupt high currents make them ideal for critical applications with inductive or other loads of up to 280 amperes.

The hydraulic-magnetic load-sensing and time delay mechanism of the Series GJ is insensitive to changes in ambient or enclosure temperature, adapting it to service conditions encountered in electric vehicles, roof-mounted air conditioners and other outdoor or “heat-loaded” equipment. Unlike thermal breakers, the GJ breaker can be loaded to rated capacity without causing nuisance tripping when ambient temperature rises. It is also well suited for protecting line-sensitive loads, such as critical data processing equipment and computers.

Options

- 1-, 2- or 3-pole models.
- Fast, medium or slow response times to accurately match load conditions.
- Auxiliary switch for signaling.
- Back connected series trip, relay or shunt configurations.
- A mounting kit assembly is available for the GJ breakers (Cat. No. 009-18155).

Features

Standard Maximum Voltages:

- GJ1, GJ2 and GJ3: 240 Vac, 50/60/400 Hz.
- GJ1: 125 Vdc.
- GJ2: 125/250 Vdc.

Breakers will be labeled with standard maximum (UL) voltage unless otherwise specified.

Maximum Current Rating:

Up to 280 amperes per pole.

Interrupting Capacities

- GJ1: 10 kA at 240 Vac
160 Vdc, 25 kA at 65 Vdc.
- GJ2/3: 18 kA at 240 Vac
10 kA at 125/250 Vdc.

Terminal Types

Standard: front-connected, pressure-wire terminals accepting copper or aluminum wire sizes from 78 to 37 mm² (6 to 300 kcmil). Back-connected and many special terminals are available. Consult Customer Service Center.

Operating Temperature Range:

-40°C to +85°C.

Fungus and Humidity Resistance

MIL-STD-202. Ferrous parts incorporate special moisture-resistant finish. Springs, cases and handles are made from fungus-resistant materials.

Shock

MIL-STD-202, Method 213.

Test Condition

100g's for 6 milliseconds (Time delay breakers only).

Vibration

MIL-STD-202, Method 24, 10 to 500 Hz, 0.06-inch total excursion on three mutually perpendicular planes (time delay breakers only). Testing completed at full rated current 50/60 Hz.

Standard Breaker Configurations

The GJ Series can be ordered in a number of standard configurations utilizing the GJ Catalog Numbering System. Once you create your catalog number, you can contact our Technical Resource Center for verification and quotations.

Custom Applications

The GJ Series is also available in a number of custom configurations to meet your specific application needs. To order a special application breaker, you can visit our Web site at www.EatonElectrical.com/heinemann for a list of custom modifications and information on how to obtain a proprietary catalog number. You may also contact the Technical Resource Center for application information and breaker selection assistance.

BASIC DIMENSIONS

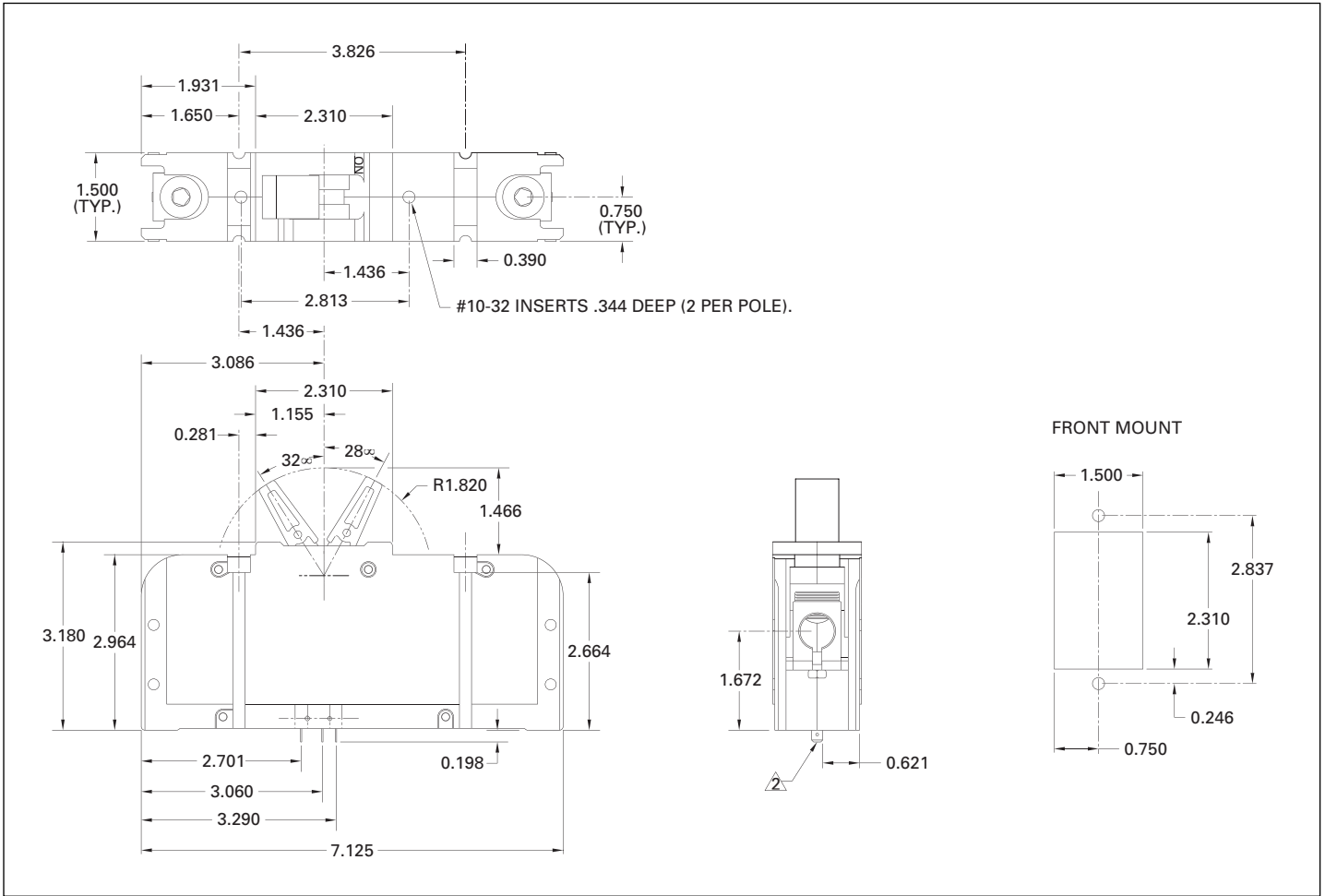

GJ CATALOG NUMBERING SYSTEM

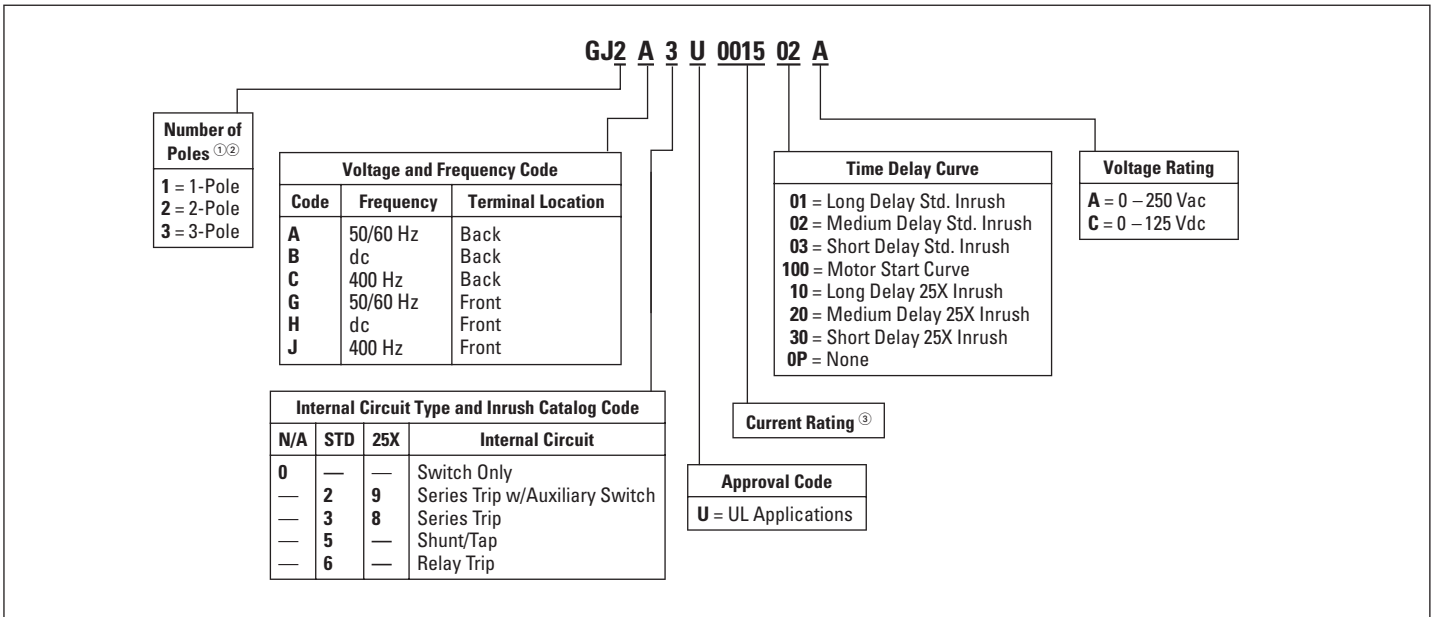

① Select from 1 to 3 poles, and enter the number in position 3 of the catalog number. For example, a GJ2 would identify a 2-pole GJ Series breaker.
 ② Style includes Toggle Handle with Black ON/OFF handle color.
 ③ Enter the four digit current rating. For example, use code "0015" for a 15 ampere current rating. Breakers are available from 100 – 280 amperes.